

**JBL**

# 2392, 2393, 2394 Large Format Optimized Aperture Bi-Radial® Horn Family

## Professional Series

### Key Features:

- ▶ Optimized Aperture™ horn design provides very low distortion at high sound pressure levels.
- ▶ Large format horn family provides uniform on and off axis frequency response from 300 Hz to above 3 kHz.
- ▶ Controlled horizontal and vertical pattern in 90° x 50°, 60° x 40°, and 40° x 30° coverage patterns.
- ▶ 76mm (3 in) throat entry.

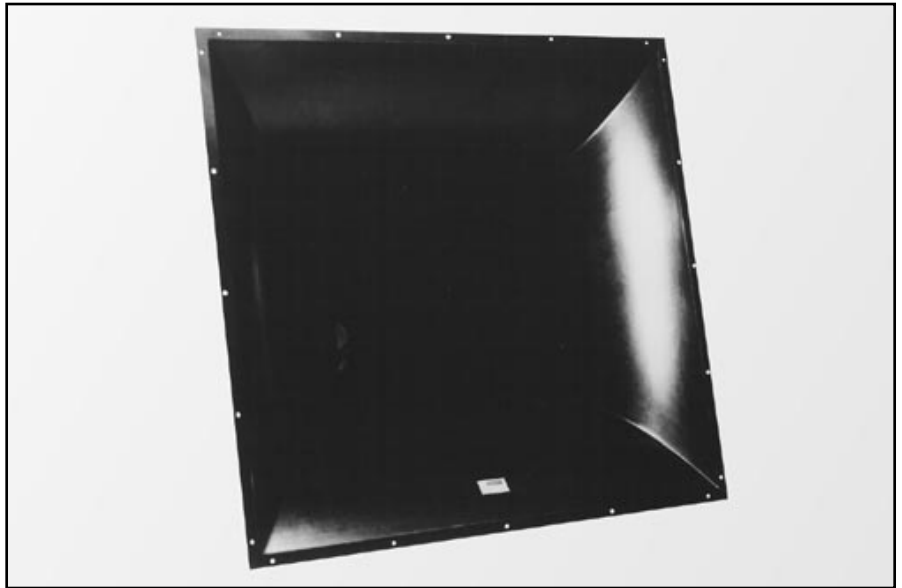

JBL models 2392, 2393, and 2394 are valuable additions to JBL's family of Bi-Radial® horns, providing uniform coverage control over the bandwidth of 300 Hz to above 3 kHz, allowing precise control of critical vocal range energy. These large format horns provide extremely low distortion at typical peak sound pressure levels of up to 145 dB-SPL at 1m (model 2394).

### Optimized Aperture -

The clear and uncolored sound character of the 2390-Series horns is accomplished by coupling the compression driver phase plug to a unique horn throat geometry, resulting in the elusive combination of extremely low throat distortion with high air movement capability. These horn designs were verified through the use of advanced technology, including finite element analysis, boundary element analysis and extensive computer modeling via proprietary JBL horn design software.

### Components and Accessories -

The 2390-Series of horns were designed to be used exclusively with the 2490H midrange compression driver. The diaphragm for this driver utilizes a three-dimensional diamond pattern surround and a pure titanium diaphragm for rigidity and freedom from breakup modes. With its 200 watt continuous program rating and optimized phase plug design for low distortion, smooth response and wide bandwidth, the 2490H is ideal for use in high level sound pressure applications.

The 2510 Mounting Bracket is recommended for suspension of the horn/driver combination. The 2510 "sandwiches" between the horn and driver providing multiple pickup points, including a slot that allows front/back alignment.

Optional Weather-Resistant versions are available, providing a 3-layer weather resistant grill and sealed chamber for the driver.

# ▶ 2392, 2393, 2394 Large Format Optimized Aperture Bi-Radial® Horn Family

## JBL 2392 Horn

Frequency response is measured on-axis to the JBL 2392 horn at a distance referenced to 1 meter at 1-watt (2.83 V rms) input in a reflection free environment.

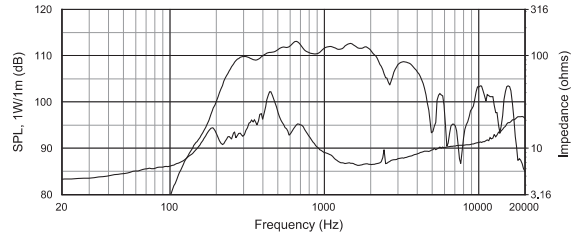

### Beamwidth vs. Frequency

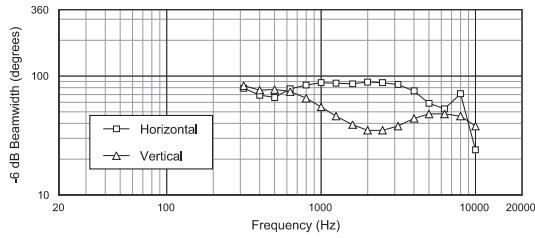

### Horizontal Off Axis Frequency Response

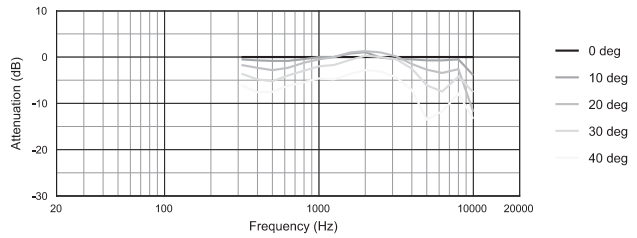

### Directivity vs. Frequency

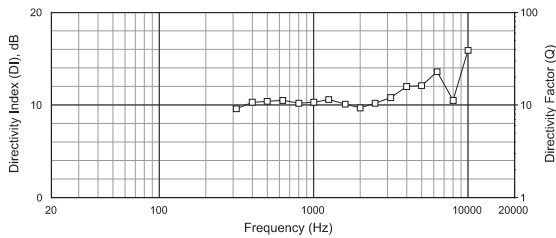

### Vertical Off-Axis Frequency Response

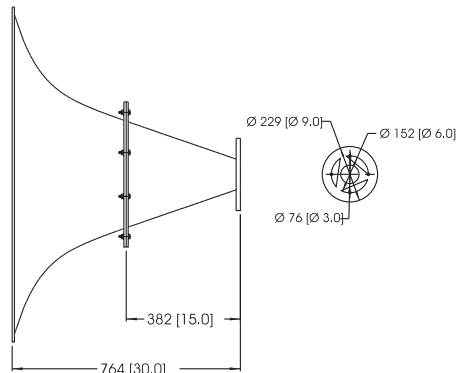
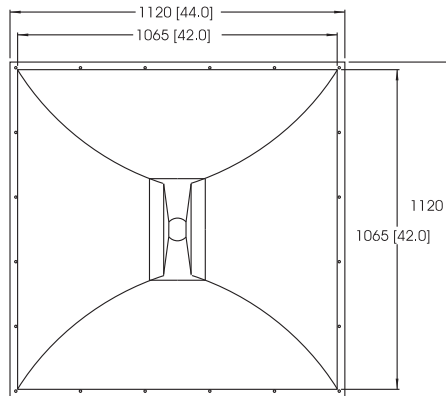
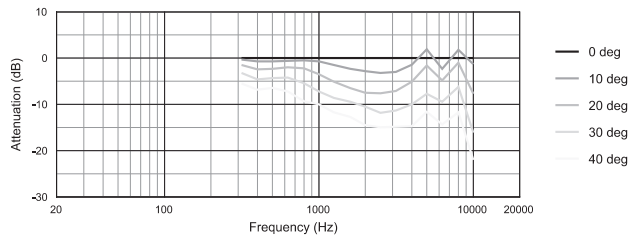

DIMENSIONS IN mm  
DIMENSIONS IN [ ] ARE INCHES

### Horizontal 1/3 Octave Polars

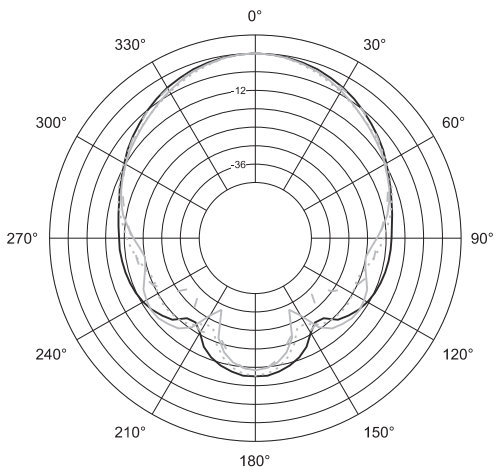

- 315Hz
- 400Hz
- ⋯ 500Hz
- - 630Hz

### Vertical 1/3 Octave Polars

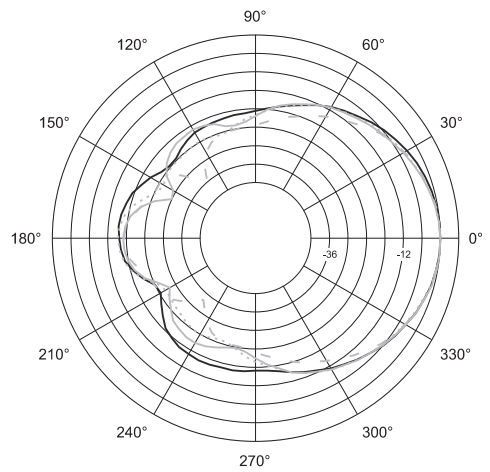

- 315Hz
- 400Hz
- ⋯ 500Hz
- - 630Hz

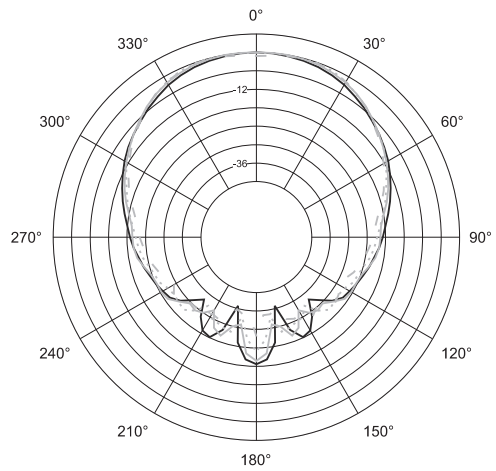

- 800Hz
- 1kHz
- ⋯ 1.25kHz
- - 1.6kHz

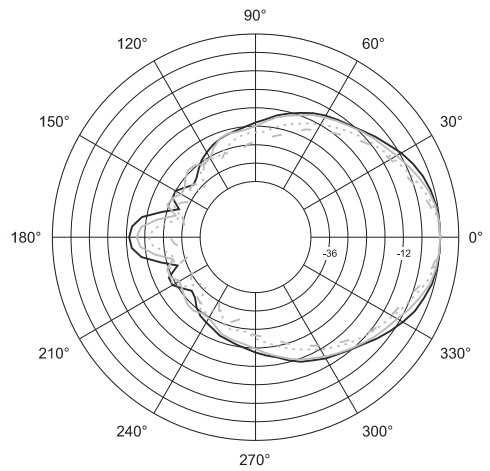

- 800Hz
- 1kHz
- ⋯ 1.25kHz
- - 1.6kHz

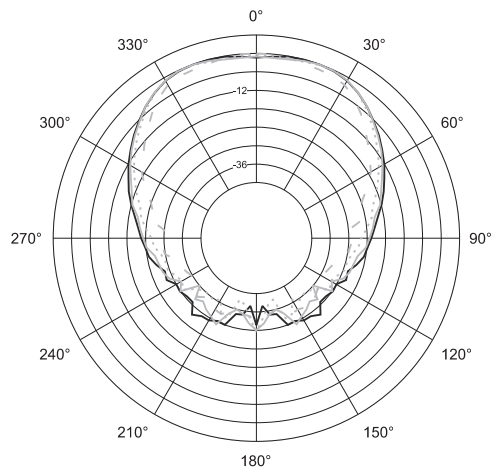

- 2kHz
- 2.5kHz
- ⋯ 3.15kHz
- - 4kHz

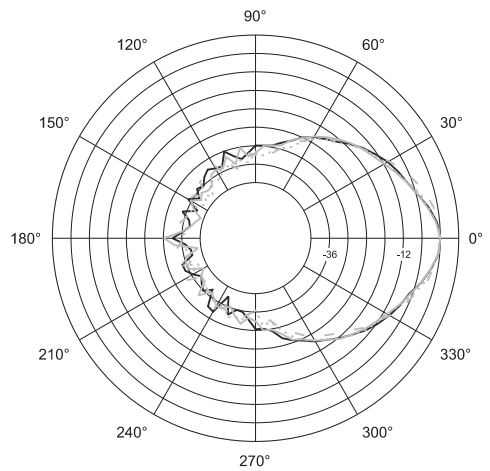

- 2kHz
- 2.5kHz
- ⋯ 3.15kHz
- - 4kHz

# ▶ 2392, 2393, 2394 Large Format Optimized Aperture Bi-Radial® Horn Family

## JBL 2393 Horn

Frequency response is measured on-axis to the JBL 2393 horn at a distance referenced to 1 meter at 1-watt (2.83 V rms) input in a reflection free environment.

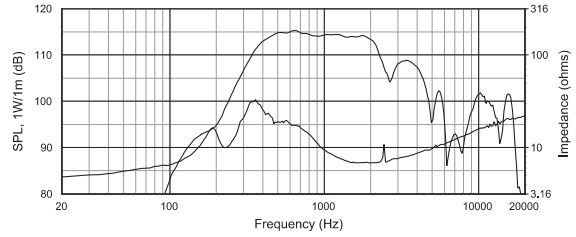

Beamwidth vs. Frequency

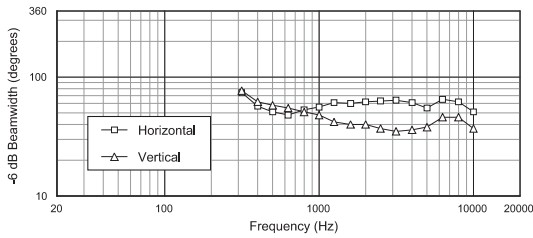

Horizontal Off Axis Frequency Response

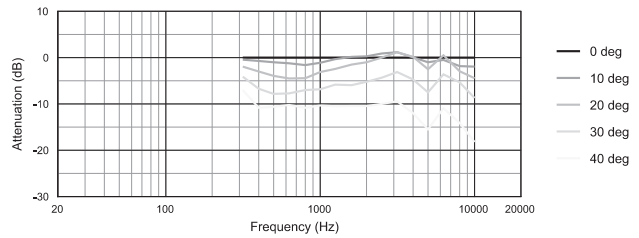

Directivity vs. Frequency

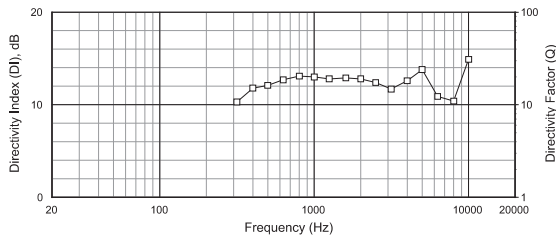

Vertical Off-Axis Frequency Response

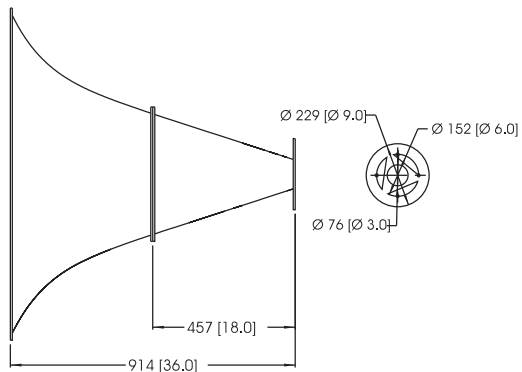
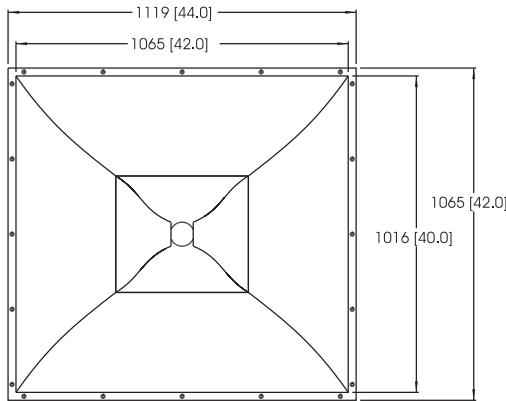
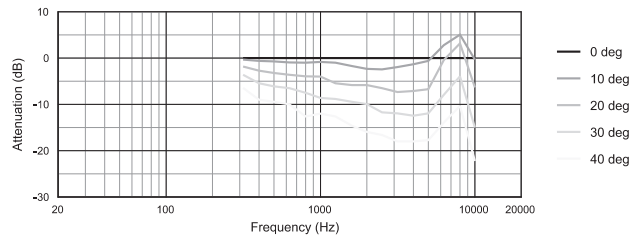

DIMENSIONS IN mm  
DIMENSIONS IN [ ] ARE INCHES

### Horizontal 1/3 Octave Polars

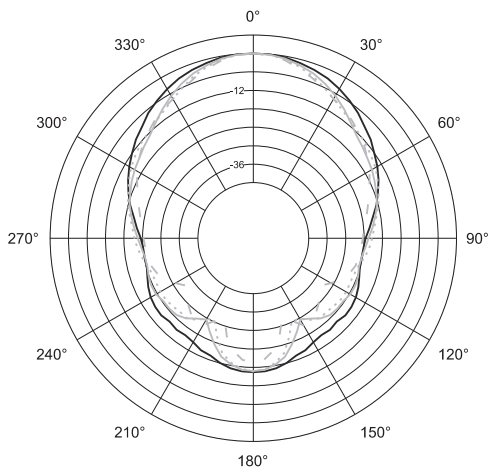

- 315Hz
- 400Hz
- 500Hz
- - 630Hz

### Vertical 1/3 Octave Polars

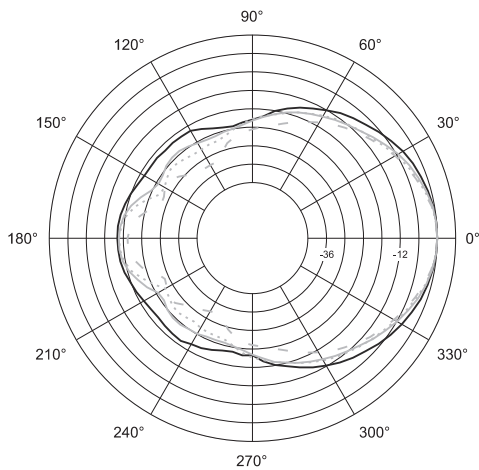

- 315Hz
- 400Hz
- 500Hz
- - 630Hz

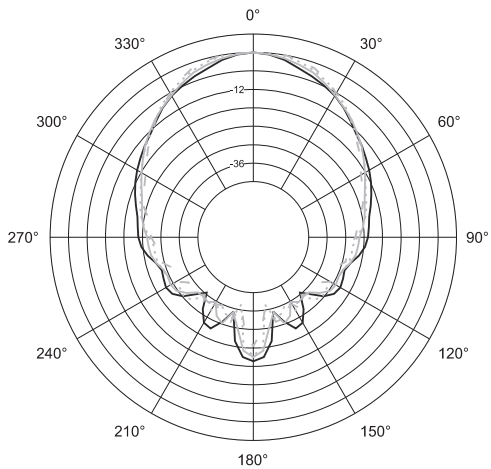

- 800Hz
- 1kHz
- 1.25kHz
- - 1.6kHz

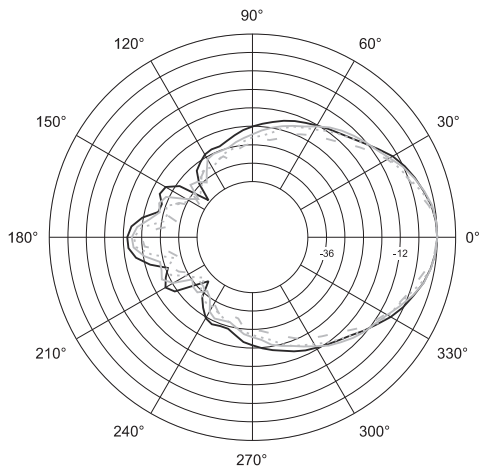

- 800Hz
- 1kHz
- 1.25kHz
- - 1.6kHz

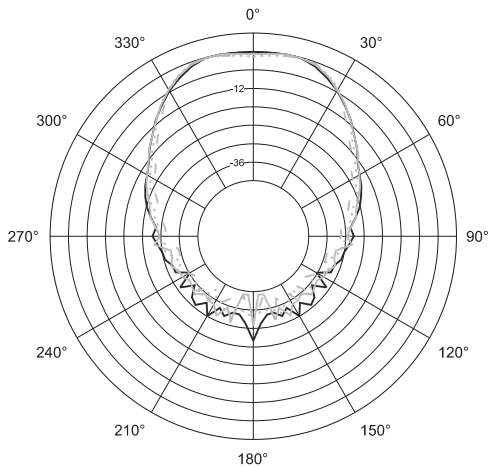

- 2kHz
- 2.5kHz
- 3.15kHz
- - 4kHz

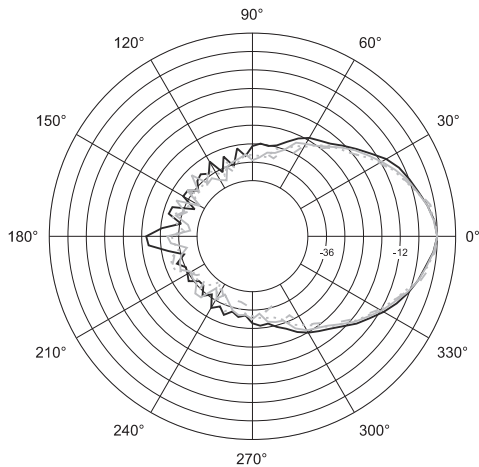

- 2kHz
- 2.5kHz
- 3.15kHz
- - 4kHz

# ▶ 2392, 2393, 2394 Large Format Optimized Aperture Bi-Radial® Horn Family

## JBL 2394 Horn

Frequency response is measured on-axis to the JBL 2394 horn at a distance referenced to 1 meter at 1-watt (2.83 V rms) input in a reflection free environment.

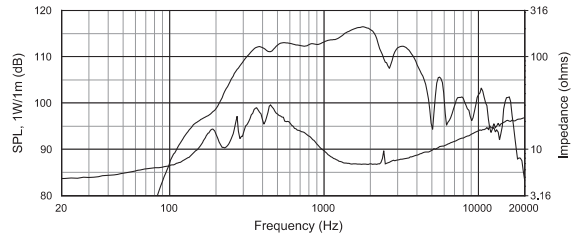

Beamwidth vs. Frequency

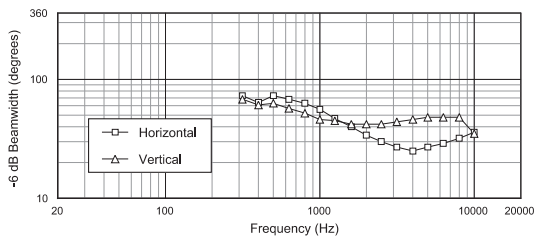

Horizontal Off Axis Frequency Response

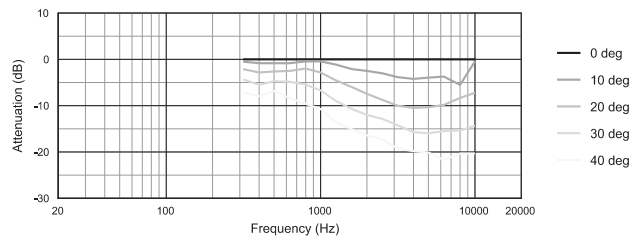

Directivity vs. Frequency

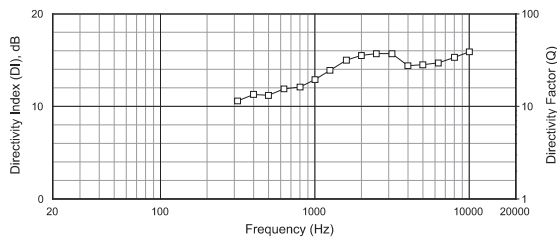

Vertical Off-Axis Frequency Response

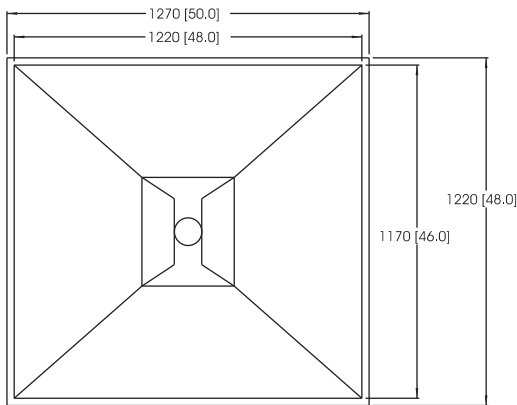
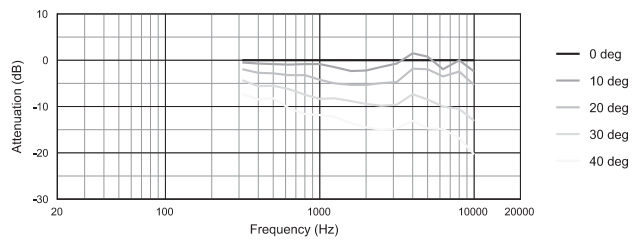

DIMENSIONS IN mm  
DIMENSIONS IN [ ] ARE INCHES

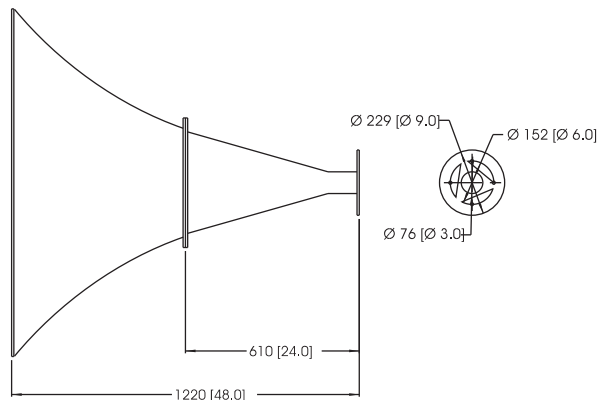

### Horizontal 1/3 Octave Polars

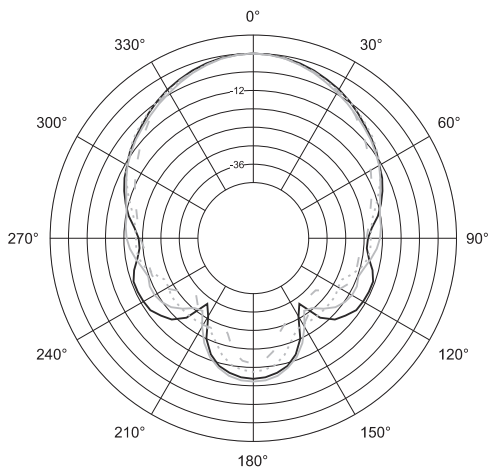

- 315Hz
- 400Hz
- 500Hz
- - 630Hz

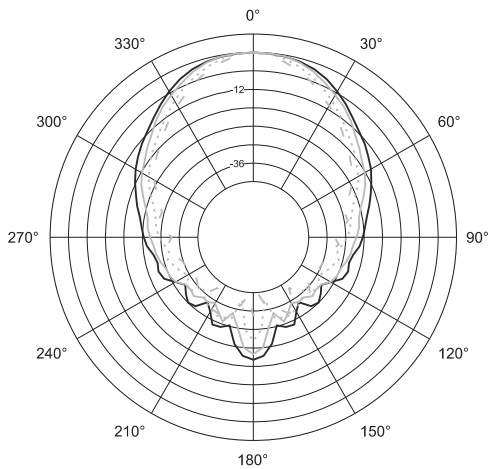

- 800Hz
- 1kHz
- 1.25kHz
- - 1.6kHz

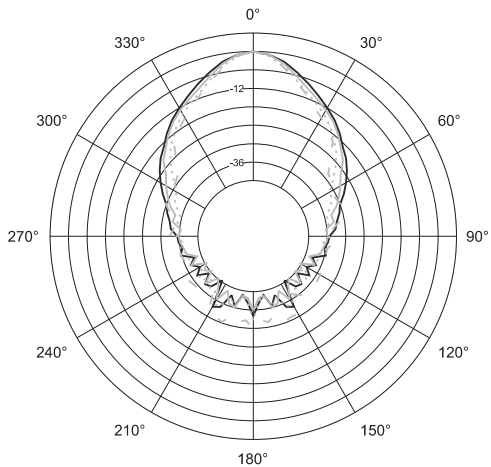

- 2kHz
- 2.5kHz
- 3.15kHz
- - 4kHz

### Vertical 1/3 Octave Polars

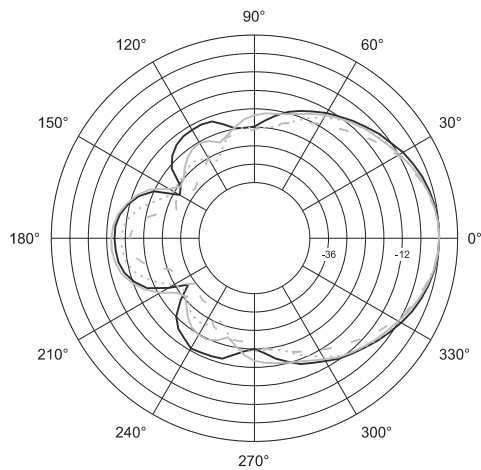

- 315Hz
- 400Hz
- 500Hz
- - 630Hz

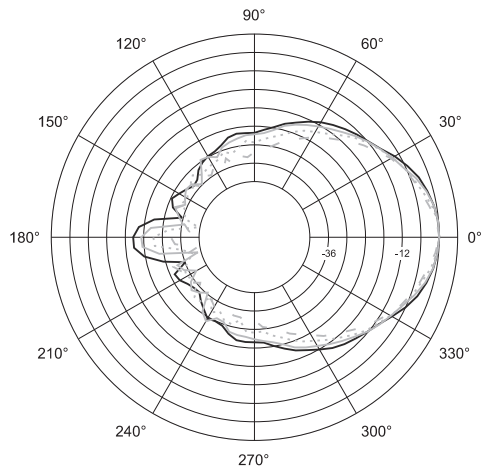

- 800Hz
- 1kHz
- 1.25kHz
- - 1.6kHz

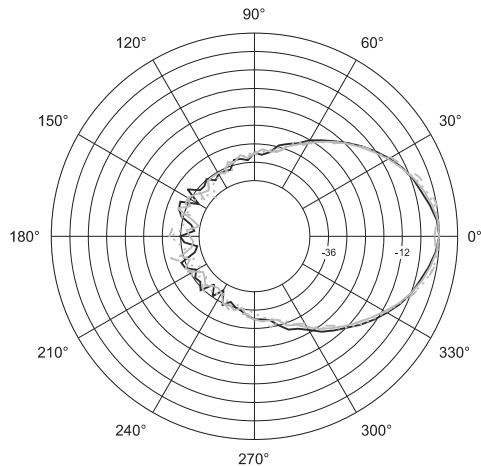

- 2kHz
- 2.5kHz
- 3.15kHz
- - 4kHz

## ▶ 2392, 2393, 2394 Large Format Optimized Aperture Bi-Radial® Horn Family

### Specifications:

Horn Model:	2392	2393	2394
Horizontal Coverage Angle (-6 dB):	90° (+5°, -10°) 300 Hz to 4 kHz	60° (+5°, -8°) 300 Hz to 4 kHz	40° (+10°, -0°) 300 Hz to 4 kHz
Vertical Coverage Angle (-6 dB):	50° (+35°, -0°) 300 Hz to 4 kHz	40° (+28°, -2°) 300 Hz to 4 kHz	30° (+25°, -5°) 300 Hz to 4 kHz
Directivity Factor (DQ):	10 (+5, -2) 300 Hz to 4 kHz	20 (+12, -10) 300 Hz to 4 kHz	33 300 Hz to 4 kHz
Directivity Index (DI):	10 (+2, -1) 300 Hz to 4 kHz	13 (+2, -3) 300 Hz to 4 kHz	15 300 Hz to 4 kHz
Axial Pressure Sensitivity <sup>1</sup> :	114 dB	115 dB	116 dB
Minimum Recommended Crossover:	300 Hz @ 18 dB/octave min.	300 Hz @ 18 dB/octave min.	300 Hz @ 18 dB/octave min.
Usable Low Frequency Limit:		300 Hz	
Calc. Max. Continuous SPL:	137 dB SPL @ 1 m	138 dB SPL @ 1 m	139 dB SPL @ 1 m
Calc. Max. Peak SPL <sup>2</sup> :	143 dB SPL @ 1 m	144 dB SPL @ 1 m	145 dB SPL @ 1 m
<b>Physical:</b>			
Construction:	Fiberglass reinforced plastic		
Mount Height:	1118 mm (44 in)	1067 mm (42 in)	1219 mm (48 in)
Mount Width:	1118 mm (44 in)	1118 mm (44 in)	1270 mm (50 in)
Length with Driver:	853 mm (33.6 in)	1005 mm (39.6 in)	1315 mm (51.6 in)
Length of each Section <sup>3</sup> :	385 mm (15 in)	460 mm (18 in)	610 mm (24 in)
Net Weight:	18 kg (40 lbs)	32.2 kg (71 lbs)	36.36 kg (80 lbs)

<sup>1</sup>Measured on axis in the far field with 1 watt (2.83 V RMS @ 8 ohms) input and referenced to 1 meter distance using the inverse square law. Listed sound pressure represents an average from 300 Hz to 16 kHz

<sup>2</sup>With 2490H driver.

<sup>3</sup>To facilitate shipping and handling this horn is made and shipped in two halves.

JBL continually engages in research related to product improvement. New materials, production methods, and design refinements are introduced into existing products without notice as a routine expression of that philosophy. For this reason, any current JBL product may differ in some respect from its published description, but will always equal or exceed the original design specifications unless otherwise stated.



JBL Professional  
8500 Balboa Boulevard, P.O. Box 2200  
Northridge, California 91329 U.S.A.

■ A Harman International Company

SS 2392/93/94  
CRP 10M  
1/98